

Before you can use the machine, you must set up the hardware and install the driver. Please read this "Quick Setup Guide" for proper set up and installation instructions.

Step 1



Setting Up the Machine

Step 2





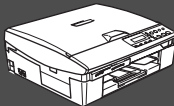

Installing the Driver & Software









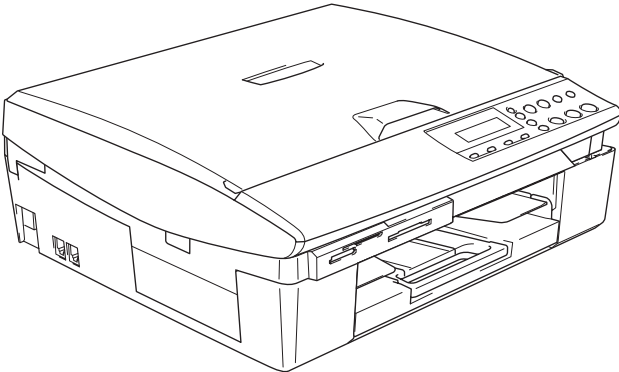
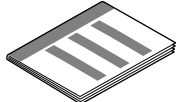
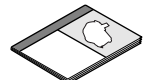

Setup is Complete!

For the latest drivers and to find the best solution for your problem or question, access the Brother Solutions Center directly from the driver or go to <http://solutions.brother.com>
Keep this "Quick Setup Guide", User's Guide and supplied CD-ROM in a convenient place for quick and easy reference at all times.

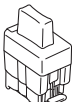
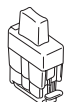
 Warning		 Hint	 User's Guide
Indicates warnings that must be observed to prevent possible personal injury.	Indicates cautions that must be observed to use the machine properly or to prevent damage to the machine.	Indicates notes and useful tips to remember when using the machine.	Indicates reference to the User's Guide.

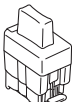
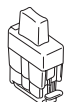
Getting Started

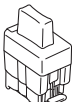
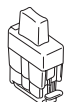
Carton Components

<p>DCP</p> 	 <p>Quick Setup Guide</p>								
 <p>Accessory Order Form</p>	 <p>CD-ROM</p>								
<table border="0"><tr><td data-bbox="295 875 416 1055"><p>Black (LC41BK)</p></td><td data-bbox="630 875 751 1055"><p>Magenta (LC41M)</p></td><td data-bbox="965 875 1086 1055"><p>Yellow (LC41Y)</p></td><td data-bbox="1300 875 1422 1055"><p>Cyan (LC41C)</p></td></tr><tr><td colspan="4" data-bbox="751 1066 954 1099"><p>Ink Cartridges</p></td></tr></table>		 <p>Black (LC41BK)</p>	 <p>Magenta (LC41M)</p>	 <p>Yellow (LC41Y)</p>	 <p>Cyan (LC41C)</p>	<p>Ink Cartridges</p>			
 <p>Black (LC41BK)</p>	 <p>Magenta (LC41M)</p>	 <p>Yellow (LC41Y)</p>	 <p>Cyan (LC41C)</p>						
<p>Ink Cartridges</p>									

Carton components may differ from one country to another.
Save all packing materials and the carton.



If you are connecting the machine via USB:

- *The interface cable is not a standard accessory. Please purchase an appropriate USB 2.0 interface cable.*
- *Please make sure you use a USB 2.0 interface cable that is no longer than 6 feet long (2 metres).*
- *Your DCP has a USB 2.0 Full-Speed interface. This interface is compatible with USB 2.0 Hi-Speed; however, the maximum data transfer rate will be 12 Mbits/s. The DCP can also be connected to a computer that has a USB 1.1 interface.*

Control Panel

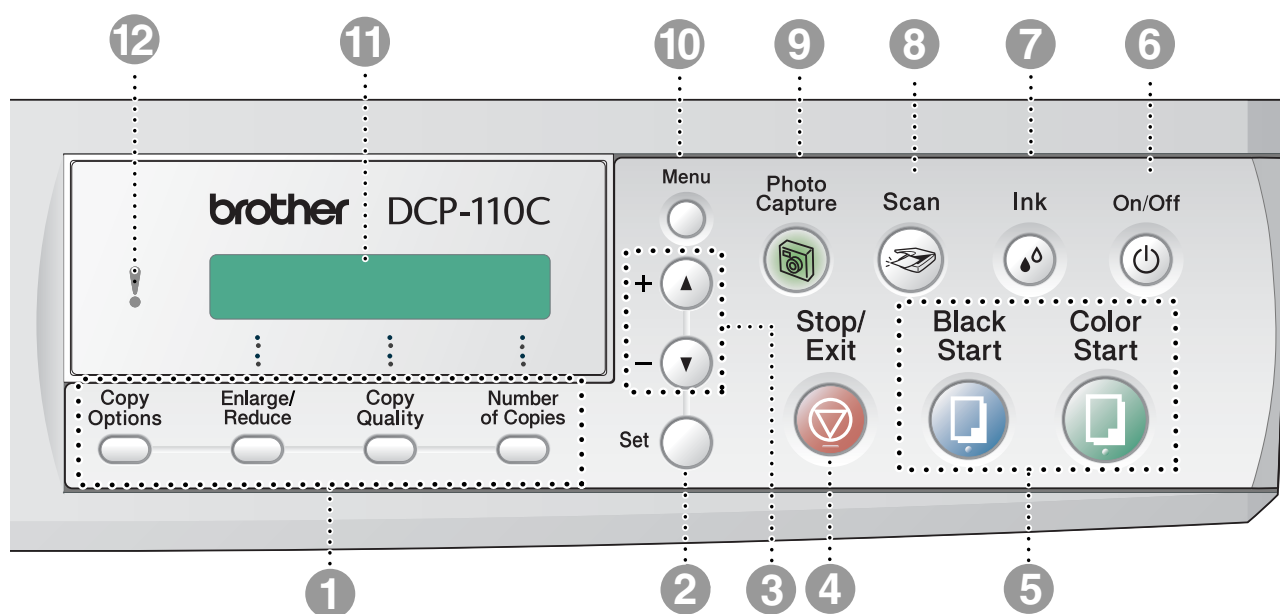

1. Copy keys	5. Start keys	9. PhotoCapture key
2. Set key	6. On/Off key	10. Menu key
3. Navigation keys	7. Ink key	11. Liquid Crystal Display (LCD)
4. Stop/Exit key	8. Scan key	12. Light-Emitting Diode (LED)



For the details of the control panel, see "Control panel overview" in Chapter 1 of the User's Guide.

Table of Contents

Step 1 **Setting Up the Machine**

1. Removing the Protective Parts	4
2. Loading Paper	4
3. Installing the Power Cord	5
4. Installing the Ink Cartridges	5
5. Print Quality Check	7
6. Selecting Your Language (Canada only)	8
7. Setting the Date and Time	9

Step 2 **Installing the Driver & Software**

Windows®	Supplied CD-ROM (MFL-Pro Suite).....	10
	For Windows® 98/98SE/Me/2000 Professional/XP.....	12
Macintosh®	For Mac OS® 8.6 to 9.2	15
	For Mac OS® X 10.2.4 or greater	17

■ **Consumables and Options**

Replacement Consumables.....	20
Option	20

Step 1

Setting Up the Machine

1 Removing the Protective Parts

- 1 Remove the protective tape.



DO NOT connect the USB cable.
Connecting the USB cable is done when installing the driver.

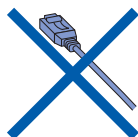

2 Loading Paper



You can load up to 100 sheets of 20 lb paper.
For more details, see "About paper" in Chapter 1 of the User's Guide.

- 1 Pull the paper tray completely out of the machine and remove the output paper tray.

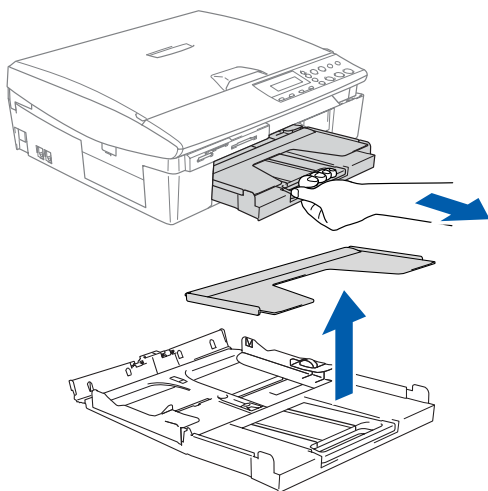

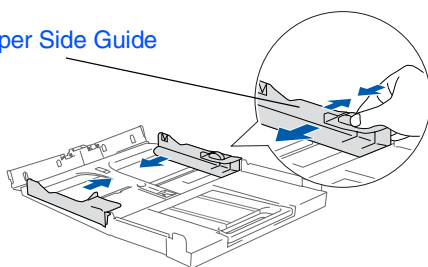

- 2 Press and slide the paper guide to fit the paper width.

Paper Side Guide

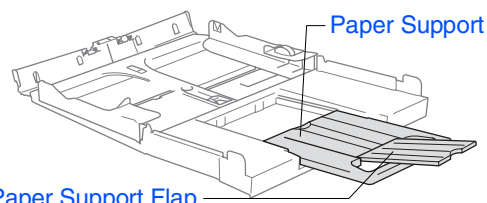

- 3 Pull out the paper support and unfold the paper support flap.



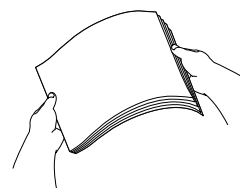

-  Use the paper support flap for Letter, Legal and A4 size paper.

- 4 Fan the stack of paper well to avoid paper jams and mis-feeds.

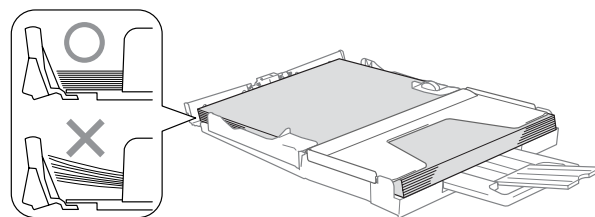
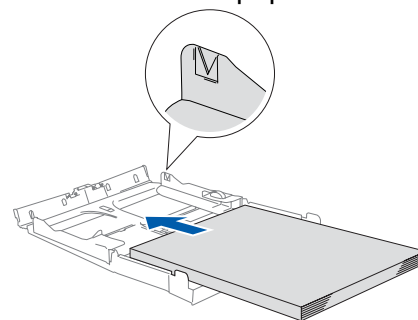

- 5 Gently insert the paper into the paper tray print side down and top edge first. Check that the paper is flat in the tray and below the maximum paper mark.



-  ■ Make sure the paper side guides touch the sides of the paper.
■ Be careful that you do not push the paper in too far; it may lift at the back of the tray and cause paper feed problems.

- 6 Put the output paper tray back on and push the paper tray firmly back into the machine.

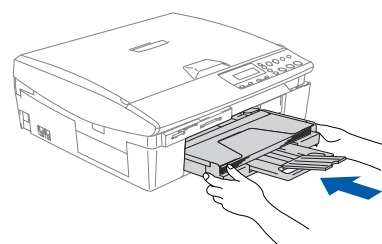

3 Installing the Power Cord

- 1 Connect the power cord.

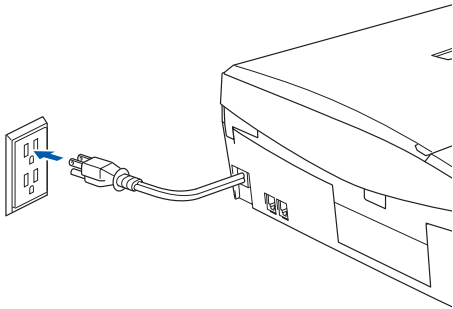

 **DO NOT connect the USB cable yet.**

Warning

The DCP must be connected to a grounded/earthed plug.

4 Installing the Ink Cartridges

Warning

If ink gets in your eyes wash them with water immediately, and if irritation occurs consult a doctor.

- 1 Make sure that the power is turned on. The LCD shows:

No Cartridge

- 2 Lift the scanner cover from the right-hand side of the DCP until it locks securely into the open position.

Scanner Cover

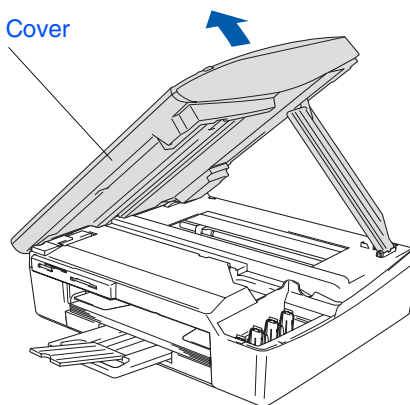

Continued...

Step 1 Setting Up the Machine

- 3 Remove the protective parts.

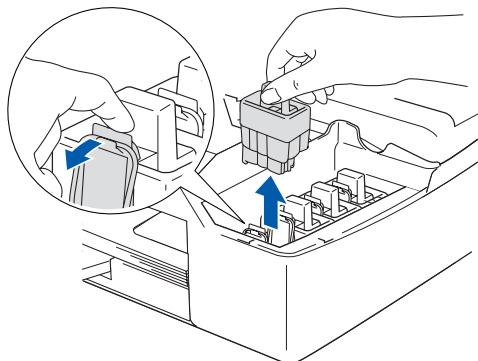

 Do not throw away the protective parts. You will need them when you transport the machine.

- 4 Take out the ink cartridge.

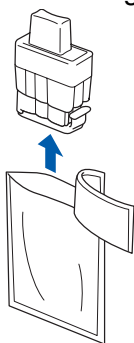



- 5 Carefully remove the bottom cap.

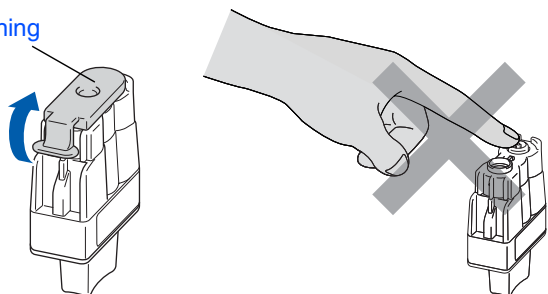

DO NOT touch the area shown in the illustration below.

Opening



 If the cartridge cover comes off when you open the bag the cartridge will not be damaged.

Keep the ink cartridge in an upright position when you insert it into the slot.

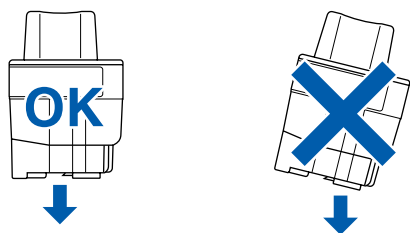

- 6 Press firmly down on the ink cartridge until the hook snaps over it, taking care to match the slot color (A) with the cartridge color (B), as shown in the diagram below.

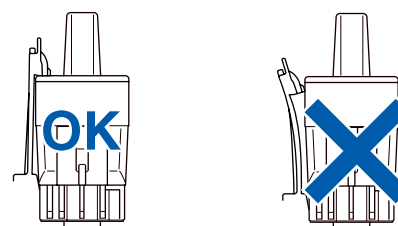
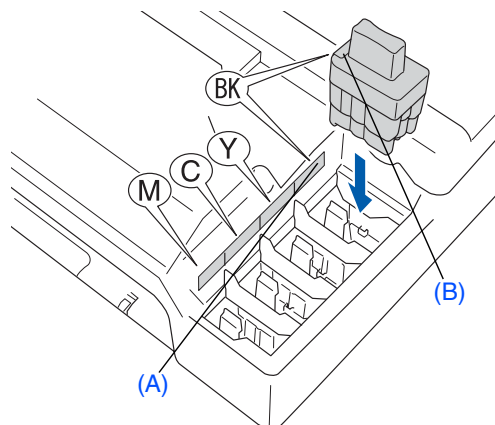

- 7 Lift the scanner cover to release the lock. Gently push the scanner cover support down and close the scanner cover.



If **Install** shows on the LCD after you install the ink cartridges, check to make sure the ink cartridges are installed correctly.

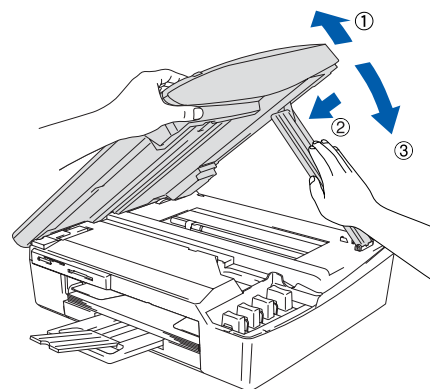

The machine will clean the ink tube system for use for the first time. This process will occur only once, the first time ink cartridges are installed. The cleaning process will last approximately four minutes.

The LCD shows:

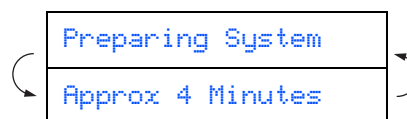



- **DO NOT** remove ink cartridges if you do not need to replace them. If you do so, it may reduce the ink quantity and the machine will not know the quantity of ink left in the cartridge.
- **DO NOT** shake the ink cartridges. If ink stains your body or clothing, wash with soap or detergent immediately.
- **DO NOT** dismantle or tamper with the ink cartridge, this can cause the ink to leak out of the cartridge.
- **Brother strongly recommends that you do not refill the ink cartridges provided with your machine. We also strongly recommend that you continue to use only Genuine Brother Brand replacement ink cartridges. Using or attempting to use potentially incompatible inks and/or cartridges in your machine may cause damage to the machine itself and/or it may result in unsatisfactory print quality. Our warranty coverage does not apply to any problem that was caused by the use of unauthorized third party ink and/or cartridges. To protect your investment and guarantee your print quality please continue to replace consumed ink cartridges with only Genuine Brother Brand Supplies.**
- **DO NOT** insert and remove the cartridges repeatedly. If you do so, the ink may seep out of the cartridge.



- *If you mix the colors by installing an ink cartridge in the wrong position, you must clean the print head by running several cleaning cycles after correcting the cartridge installation. (See "Cleaning the print head" in chapter 5 Troubleshooting and Routine Maintenance of the User's Guide.)*
- *Once you open an ink cartridge, install it in the machine and use it up within six months of installation. Use unopened ink cartridges by the expiration date written on the cartridge package.*

5

Print Quality Check

- 1 After the cleaning cycle is finished, the LCD shows:

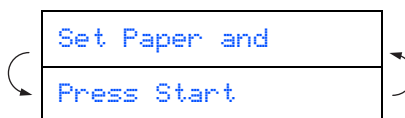

- 2 Make sure the paper is loaded in the paper tray.
Press **Color Start**.

- 3 The machine starts printing the PRINT QUALITY CHECK SHEET (only during initial ink cartridge installation).

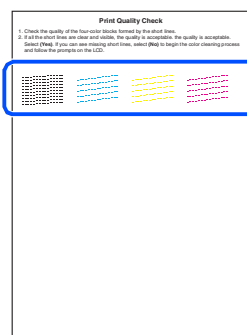

Avoid touching the printed surface of the paper immediately after printing, the surface may not be completely dry and may stain your fingers.

- 4 The LCD shows:

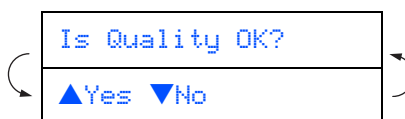

Check the quality of the four color blocks formed by the short lines printed on the sheet.
(BLACK/ CYAN/ YELLOW/ MAGENTA)

Continued...

Step 1

Setting Up the Machine

- 5 If all lines are clear and visible, press ▲ to finish the quality check.
---OR---
If you can see missing short lines, press ▼ and go to 6.

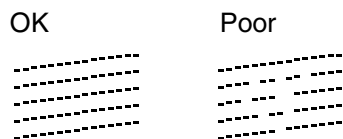

- 6 The LCD asks you if the print quality is OK for black and color. Press ▲ or ▼ on the control panel.

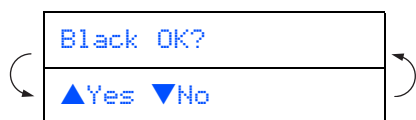

After making your selection ▲ (Yes) or ▼ (No) for black and color, the LCD shows:

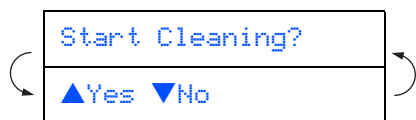

Press ▲ (Yes), the machine will then start cleaning the colors.

After cleaning is finished, press **Color Start**. The machine starts printing the PRINT QUALITY CHECK SHEET again and goes back to step 3.

6 Selecting Your Language (Canada only)

- 1 Press **Menu**.
 - 2 Press ▲ or ▼ to select 0. *Initial Setup*. Press **Set**.
 - 3 Press ▲ or ▼ to select 0. *Local Language*. Press **Set**.
 - 4 Press ▲ or ▼ to select your language (English or French). Press **Set**.
- 
- 5 Press **Stop/Exit**.

7

Setting the Date and Time

Setting the date and time allows the machine to clean the print head regularly and maintain optimum print quality. It also allows the machine to name files created when using the Scan to Card feature.

- 1 Press **Menu**.
- 2 Press ▲ or ▼ to select **0.Initial Setup**, and then press **Set**.
- 3 Press ▲ or ▼ to select **1.Date/Time**, and then press **Set**.
- 4 Press ▲ repeatedly to enter the last two digits of the year, and then press **Set**.

(e.g. Enter **0 4** for 2004.)
- 5 Press ▲ repeatedly to enter the two digits for the month, and then press **Set**.

(e.g. Enter **0 3** for March.)
- 6 Press ▲ repeatedly to enter the two digits for the day, and then press **Set**.

(e.g. Enter **0 1**.)
- 7 Press ▲ repeatedly to enter the two digits for the hour in 24-hour format, and then press **Set**.

(e.g. Enter **1 5** for 3:00 P.M.)

- 8 Press ▲ repeatedly to enter the two digits for the minute, and then press **Set**.

(e.g. Enter **1 5, 2 5** for 3:25 P.M.)



You can increase or decrease the number at a stretch by holding down ▲ or ▼.

- 9 Press **Stop/Exit**.



If you want to repeat from step 1, press **Stop/Exit**.



To confirm the current date and time, print out the **User Settings Report**. (See "Printing reports" of Appendix in the User's Guide)

Continue to Step 2, Installing the Driver & Software

Supplied CD-ROM (MFL-Pro Suite)

The CD-ROM includes the following items:

Windows®



MFL-Pro Suite includes Printer Driver, Scanner Driver, ScanSoft® PaperPort® 9.0SE, ScanSoft® OmniPage® and True Type fonts. PaperPort® 9.0SE is a document management application for viewing scanned documents. ScanSoft® OmniPage®, which is integrated into PaperPort® 9.0SE, is an OCR application that converts an image into text and inserts it into your default word processor.

Macintosh®



*1 The User's Guide on the CD-ROM includes the Software for features available when connected to a computer (e.g. Printing and Scanning).



Install MFL-Pro Suite

You can install the MFL-Pro Suite software and multifunction drivers.



Install Optional Applications

You can install additional MFL-Pro Suite software utilities.



Documentation*1

View the User's Guide and other documentation in PDF format. (Viewer included)



On-Line Registration

You will be pointed to the Brother Product Registration Web page for quick registration of your machine.



Brother Support

View contact information for Brother Customer Service and how to locate a Brother Authorized Service Center.



Repair MFL-Pro Suite

If you experience errors while installing the MFL-Pro Suite you can use this function to automatically repair and re-install the software.



Start Here

You can install the printer driver, scanner driver and Presto!® PageManager® for Mac OS® 8.6 - 9.2.



Start Here OSX

You can install the printer driver, scanner driver and Presto!® PageManager® for Mac OS® 10.2.4 or greater.



Readme!

You can get important information and troubleshooting tips.



Documentation*1

View the User's Guide and other documentation in PDF format.



Brother Solutions Center

You can access the Brother Solutions Center which is a Web site offering information about your Brother product including FAQs, User's Guides, Driver updates and Tips for using your machine.



On-Line Registration

You will be pointed to the Brother Product Registration Web Page for quick registration of your machine.



Follow the instructions on this page for your operating system.

Setting Up
the Machine

Windows®



■ For Windows® 98/98SE/Me/2000 Professional/XP..... Go to page 12

Windows®

Macintosh®



■ For Mac OS® 8.6 to 9.2..... Go to page 15

Mac OS®
8.6 - 9.2



■ For Mac OS® X 10.2.4 or greater Go to page 17

Mac OS® X

For Windows® 98/98SE/Me/2000 Professional/XP

Make sure that you have completed the instructions from Step 1 “Setting Up the Machine” on pages 4 - 9.

If you are using Windows® 2000 Professional:

To access the PhotoCapture Center™ features from your PC you may have to install a Windows® 2000 update first.

The Windows® 2000 update is included with the MFL-Pro Suite installer.

To install the update, follow the steps below:

1. Follow the installation steps from 1 to 4.
2. Click **OK** to start installation of the update.
3. When instructed, click **OK** to restart your PC.
4. After the PC restarts, the installation of MFL-Pro Suite will automatically continue.



- If the installation does not continue automatically, please open the MFL-Pro Suite installer menu again by ejecting then reinserting the CD-ROM disc or double-click the **setup.exe** program from the root directory, and continue from Step 4 to install the MFL-Pro Suite.
- Make sure there are no media cards inserted into the media drive of the machine.
- Brother recommends you connect the machine directly to your computer.
- Please close any applications running before installing the MFL-Pro Suite.

- 1 Disconnect the machine from the AC outlet and from your computer, if you have already connected an interface cable.

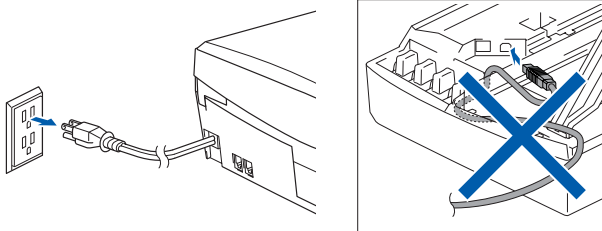

- 2 Turn on your computer. (For Windows® 2000 Professional/XP, you must be logged on as the administrator.)
- 3 Insert the supplied CD-ROM into your CD-ROM drive. If the model name screen appears, select your machine. If the language screen appears, select your language.



- 4 The CD-ROM main menu will appear. Click **Install MFL-Pro Suite**.



If this window does not appear, use Windows® Explorer to run the **setup.exe** program from the root directory of the Brother CD-ROM.



If you see the following screen, click **OK** to install the Windows® updates. After the updates are installed your PC may restart. Note: If it does the installation will automatically continue.

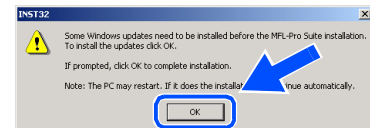

If the installation does not continue automatically, please open the main menu again by ejecting then reinserting the CD-ROM disc or double-click the **setup.exe** program from the root directory, and continue from Step 4 to install the MFL-Pro Suite.

- 5 After reading and accepting the ScanSoft® PaperPort® 9.0SE License Agreement, click **Yes**.

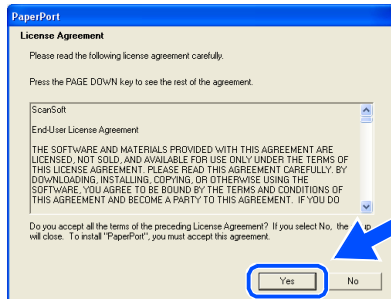

- 6 The installation of PaperPort® 9.0SE will automatically start and is followed by the installation of MFL-Pro Suite.

- 7 When the Brother MFL-Pro Suite Software License Agreement window appears, click **Yes**, if you agree to the Software Licence Agreement.

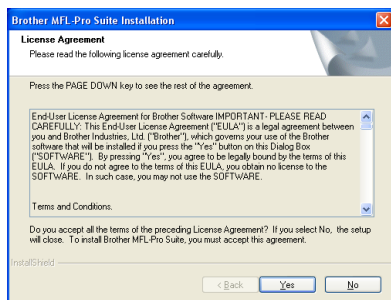

- 8 Select **Local Connection**, and then click **Next**. The installation will continue.

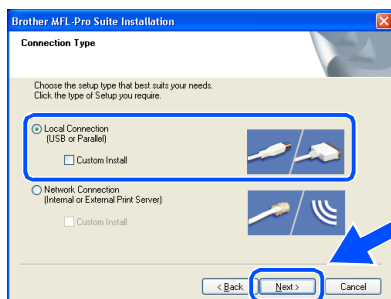

- 9 When this screen appears, connect the USB interface cable to your PC, and then connect it to the machine.

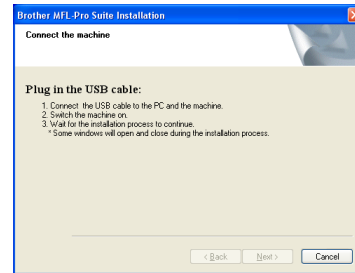

To connect the USB cable to the machine:

1. Open the scanner cover to its open position.
2. Insert the USB cable into the USB socket, marked with a  symbol. You will find the USB socket above and to the left of the ink cartridge slots, as shown below.

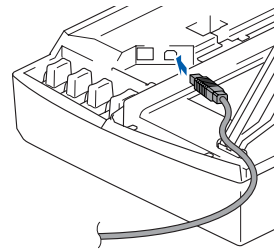

3. Carefully route the USB cable through the trench and out the back of the machine as shown below.

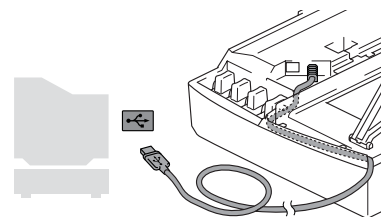

Warning

Ensure that the cable does not restrict the cover from closing, or an error may occur.



DO NOT connect the machine to a USB port on a keyboard or a non powered USB hub.

Continued...

For Windows® 98/98SE/Me/2000 Professional/XP

- 10 Lift the scanner cover to release the lock. Gently push the scanner cover support down and close the scanner cover.
- 11 Turn on the machine by plugging in the power cord.

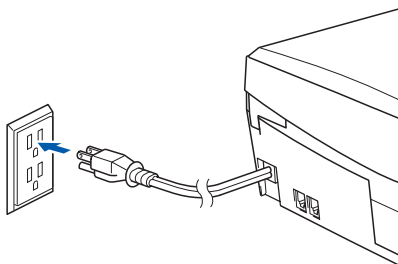

It will take a few seconds for the installation screen to appear. The installation of the Brother drivers will automatically start. The installation screens appear one after another, please wait for a while.

- 12 When the Brother and ScanSoft on-line Registration screen is displayed, make your selection and follow the on-screen instructions.

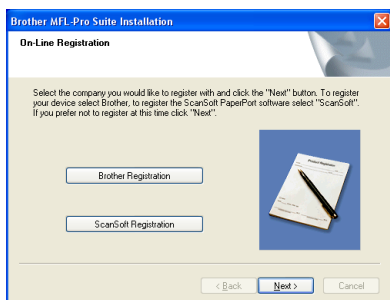

- 13 Click **Finish** to restart your computer.

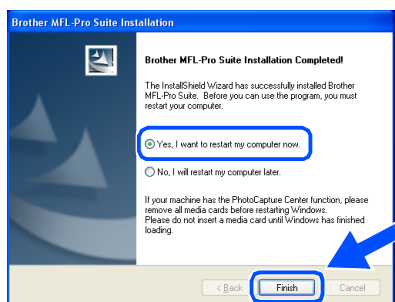

- 14 After restarting the computer, the Installation Diagnostics will run automatically and the installation results window will be shown.



*If the installation is unsuccessful try installing again using the **Repair MFL-Pro Suite** option from the main menu. Select **Repair MFL-Pro Suite** and follow the instructions on the screen.*

- OK!** The MFL-Pro Suite, Brother Printer driver and Scanner driver have been installed and the installation is now complete.

For Mac OS® 8.6 to 9.2

Make sure that you have completed the instructions from Step 1 “Setting Up the Machine” on pages 4 - 9.

- 1 Disconnect the machine from the AC outlet and from the Macintosh®, if you have already connected an interface cable.

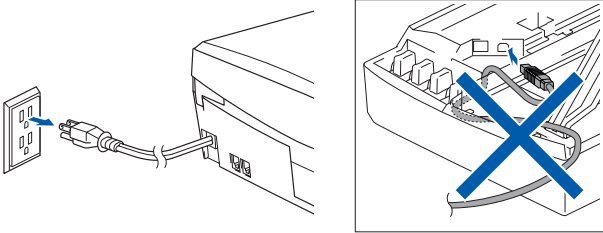

- 2 Turn on your Macintosh®.
- 3 Insert the supplied CD-ROM into your CD-ROM drive.



- 4 Double-click the **Start Here** icon to install the printer and scanner drivers. If the language screen appears, select your language.

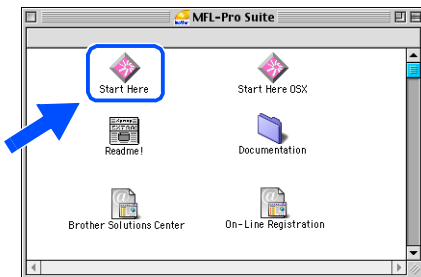

- 5 Click **MFL-Pro Suite** to install.



- 6 Follow the on-screen instructions, and restart your Macintosh®.

- 7 Connect the USB interface cable to your Macintosh®, and then connect it to the machine.

To connect the USB cable to the machine:

1. Open the scanner cover to its open position.
2. Insert the USB cable into the USB socket, marked with a  symbol. You will find the USB socket above and to the left of the ink cartridge slots, as shown below.

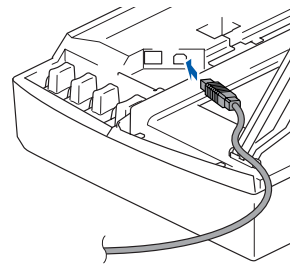

3. Carefully route the USB cable through the trench and out back of the machine as shown below.

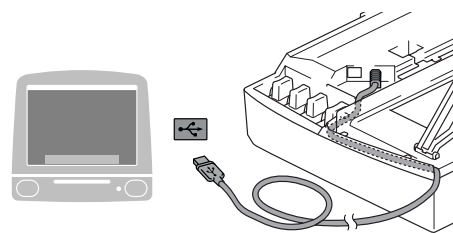

Warning

Ensure that the cable does not restrict the cover from closing, or an error may occur.



DO NOT connect the machine to a USB port on a keyboard or a non powered USB hub.

Continued...

- 8 Lift the scanner cover to release the lock. Gently push the scanner cover support down and close the scanner cover.
- 9 Turn on the machine by plugging in the power cord.

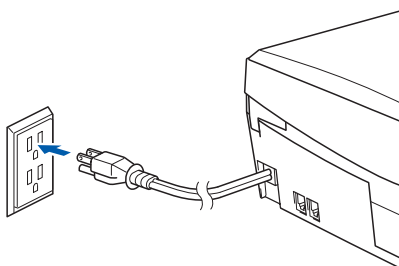

- 10 From the Apple® menu, open the **Chooser**.



- 11 Click the **Brother Ink** icon you installed. On the right side of the **Chooser**, select the printer to which you want to print. Close the **Chooser**.

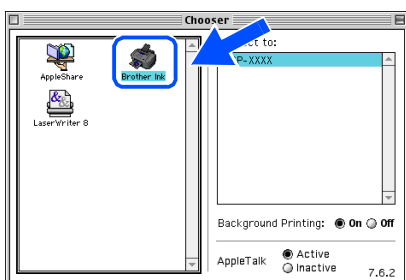

- OK! The **Brother Printer driver and Scanner driver** have been installed.

- 12 To install Presto!® PageManager®, click the **Presto! PageManager** icon and follow the on-screen instructions.



 You can easily scan, share and organize photos and documents using Presto!® PageManager®.

- OK! **Presto!® PageManager®** has been installed and the installation is now complete.

For Mac OS® X 10.2.4 or greater

Make sure that you have completed the instructions from Step 1 “Setting Up the Machine” on pages 4 - 9.



For Mac OS® X 10.2.0 to 10.2.3 user, please upgrade to Mac OS® X 10.2.4 or greater. (The latest information for Mac OS® X, please visit at: <http://solutions.brother.com>)

- 1 Disconnect the machine from the AC outlet and from the Macintosh®, if you have already connected an interface cable.

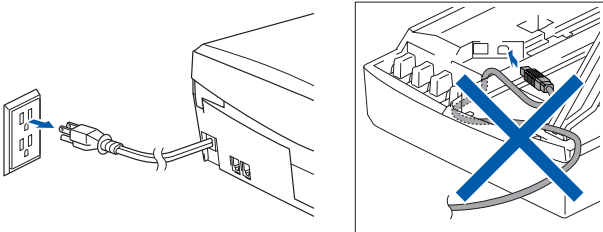

- 2 Turn on your Macintosh®.
- 3 Insert the supplied CD-ROM into your CD-ROM drive.



- 4 Double-click the **Start Here OSX** icon to install the printer driver and scanner driver. If the language screen appears, select your language.

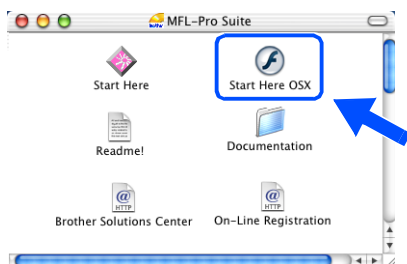

- 5 Click **MFL-Pro Suite** to install.



- 6 Follow the on-screen instructions, and restart your Macintosh®.
- 7 After the **DeviceSelector** window appears, connect the USB interface cable to your Macintosh® and then to the machine.



The **DeviceSelector** window will not appear if the USB interface cable has been connected before restarting your Macintosh® or if you are overwriting a previously installed version of the Brother Software. If you encounter this problem continue with the installation skipping step 10 and then see the Software User's Guide Chapter 8 for details on selecting what machine the ControlCenter2.0 will connect with.

To connect the USB cable to the machine:

1. Open the scanner cover to its open position.
2. Insert the USB cable into the USB socket, marked with a  symbol. You will find the USB socket above and to the left of the ink cartridge slots, as shown below.

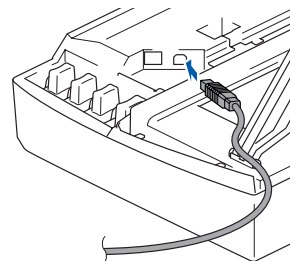

Continued...

- Carefully route the USB cable through the trench and out the back of the machine as shown below.

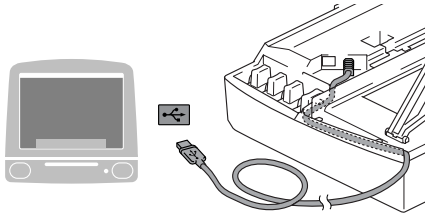

Warning

Ensure that the cable does not restrict the cover from closing, or an error may occur.



DO NOT connect the machine to a USB port on a keyboard or a non powered USB hub.

- Lift the scanner cover to release the lock. Gently push the scanner cover support down and close the scanner cover.
- Turn on the machine by plugging in the power cord.

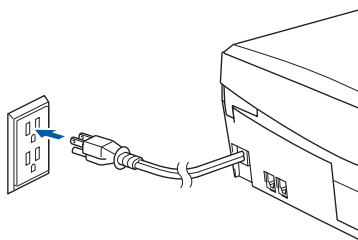

- If the **DeviceSelector** window is open, select **USB**, and then click **OK**.

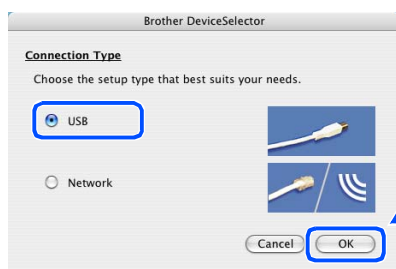

- Select **Applications** from the **Go** menu.

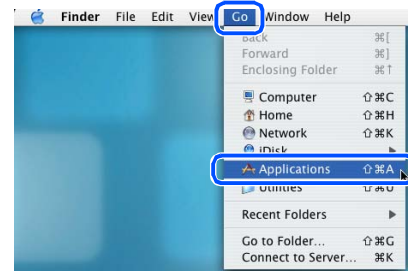

- Open the **Utilities** folder.

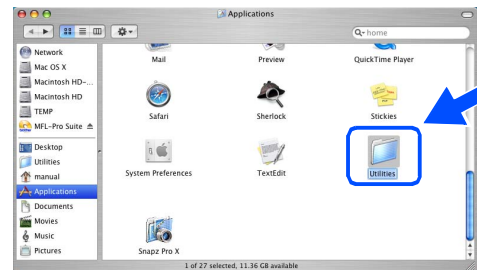

- Open the **Print Center** icon.



- Click **Add**.

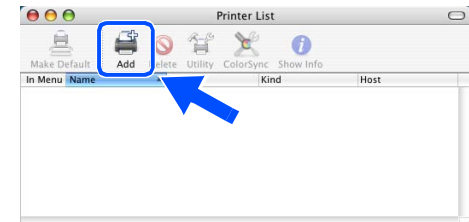

- 15 Select **USB**.

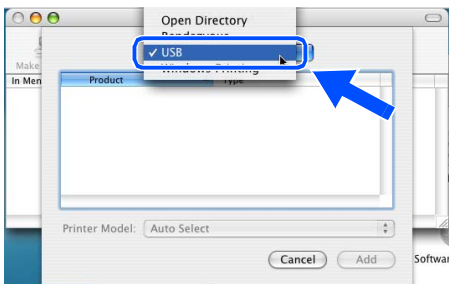

- 16 Select **DCP-110C** and then click **Add**.

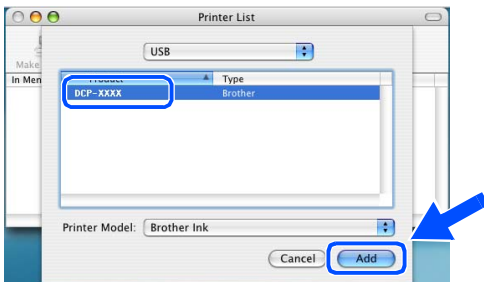

- 17 Select **Quit Printer Setup Utility** from the **Printer Setup Utility** menu.



- OK! The MFL-Pro Suite, Brother Printer driver and Scanner driver have been installed and the installation is now complete.

- 18 To install Presto!® PageManager®, click the **Presto! PageManager** icon and follow the on-screen instructions.

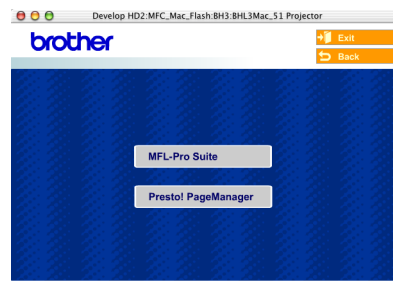

You can easily scan, share and organize photos and documents using Presto!® PageManager®.

- OK! Presto!® PageManager® has been installed and the installation is now complete.

■ Consumables and Options

Replacement Consumables

Ink Cartridge

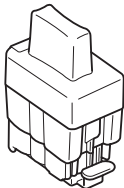
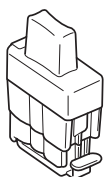
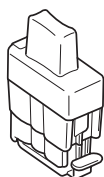
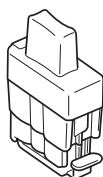
Black	Magenta	Yellow	Cyan
LC41BK	LC41M	LC41Y	LC41C
			

Option

The external wireless Print/Scan server (802.11b) is available for Brother DCP's as an option.

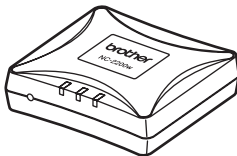
External Wireless Print/Scan Server
NC-2200w

The optional External Wireless Print/Scan Server (NC-2200w) provides wireless network printing and network scanning capabilities.



- Requires USB 2.0 cable (not included).
- Supports Mac OS® X 10.2.4 or greater.
- You can assign the scan key to one networked computer only.

Trademarks

The Brother logo is a registered trademark of Brother Industries, Ltd.

Brother is a registered trademark of Brother Industries, Ltd.

Multi-Function Link is a registered trademark of Brother International Corporation.

Windows, Microsoft and MS-DOS are registered trademarks of Microsoft in the U.S. and other countries.

Macintosh and True Type are registered trademarks of Apple Computer, Inc.

PaperPort and OmniPage are registered trademarks of ScanSoft, Inc.

Presto! PageManager is a registered trademark of NewSoft Technology Corporation.

Each company whose software title is mentioned in this manual has a Software License Agreement specific to its proprietary programs.

All other brand and product names mentioned in this manual are registered trademarks of their respective companies.

Compilation and Publication

Under the supervision of Brother Industries Ltd., this manual has been compiled and published, covering the latest product descriptions and specifications.

The contents of this manual and the specifications of this product are subject to change without notice.

Brother reserves the right to make changes without notice in the specifications and materials contained herein and shall not be responsible for any damages (including consequential) caused by reliance on the materials presented, including but not limited to typographical and other errors relating to the publication.

This product is designed for use in a Professional Environment.

brother®